

Modular Studios

From small, standard Voice-Over booths to large, custom-designed TV production studios



www.iac-australia.com.au



making the world a quieter place

IAC Acoustics

Making the World a Quieter Place

Founded on an unrivalled history of engineering with some of the most pioneering discoveries in the industry, the IAC Acoustics brand is synonymous with technological innovation.

From controlling noise at a power station to tuning the sound in a TV or radio studio, IAC Acoustics has had a positive impact on society and helped to shape what can be achieved to make speech more intelligible, music more enjoyable, reduce the impact of industrial noise and protect people's sense of hearing.

The continual success of our products and services over the decades has brought the brand a reputation for quality and reliability among customers, whether they are multinational corporations or independent family businesses. This is supported by the expertise and passion of our workforce, the people behind the products, including designers, engineers and industry specialists.

To face the ever increasing noise reduction demands of the future, we will strive to further enhance our ability to reduce excessive noise. We aim to focus on developing tomorrow's solution today, innovating faster and delivering solutions that meet the requirements of the next generation. In doing so, we will stay true to our key values and founding philosophy to make the world a quieter place.



Modular Acoustic Studios

IAC Acoustics has designed and built modular studios, control / editing rooms and Voice-Over booths for many of the world's leading broadcast, post-production and sound recording organisations, often to very demanding technical standards and very tight timescales.

Whether you require a simple, standard off-the-shelf acoustic booth for Voice-Over work or a 5000ft² TV production studio, IAC Acoustics has the product range, expertise and experience to provide the perfect design and engineered solution.

Features and Benefits

- Guaranteed Acoustic Performance
- Full Project Management Service
- Comprehensive product range, from small, standard Voice-Over booths to large, custom-designed TV production studios
- Rapid, clean installation with the option to dismantle and re-locate structures at a later date
- Over 40 years experience in broadcast and audio studio design
- BS EN ISO 9001 quality registered

Individual Components

IAC Acoustics manufactures a wide range of acoustic components which can be purchased individually. These include Noise-Lock[®] acoustic doors and windows, Moduline[®] floating floors, Varitone[®] sound absorptive wall panels and Quiet-Duct[®] air conditioning silencers.

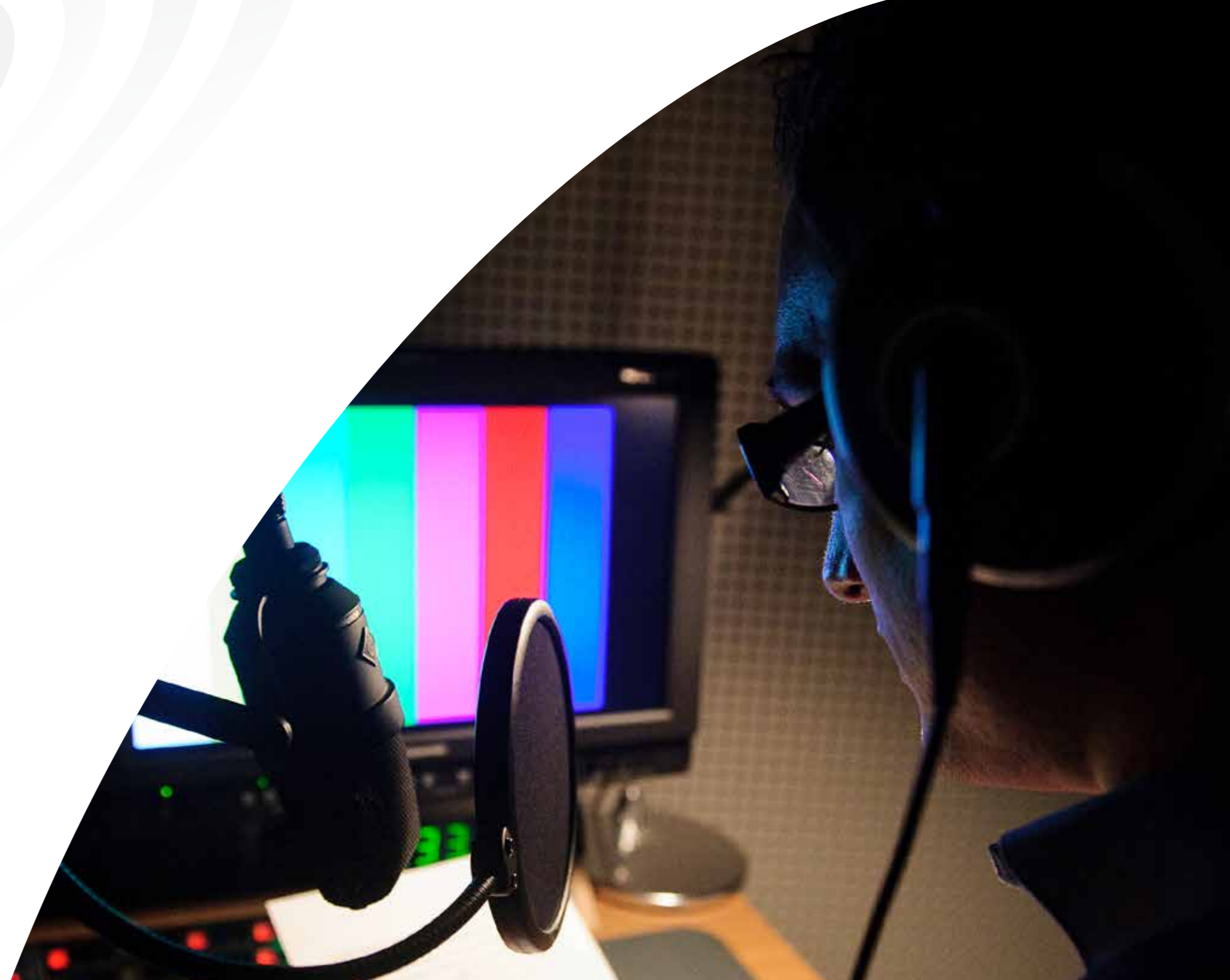

Product Range

- Single or double-wall Voice-Over booths, fully customised or chosen from a range of 6 standard models (see next page)
- TV/Film/Video production studios
- Music practice Rooms
- Voice-Over Booths
- Radio, post-production and audio studios, control/editing rooms and booths, designed and built to exactly the size, shape and specification you require
- Mobile (vehicle-mounted) studios and control rooms



What is Modular Construction?

IAC Acoustics studios are constructed using a proven system of acoustically-rated modular components which combine to create complete structures of outstanding acoustic quality.

Walls, floors and ceilings are assembled from prefabricated 100mm thick acoustic panels, into which high-performance Noise-Lock® acoustic doors and windows can be incorporated in almost any configuration.

The finishing of IAC Acoustic studios is equally flexible; air conditioning, lighting, electrics, wall/floor coverings and a host of other accessories give each studio an attractive and highly individual appearance.

Advantages of the IAC Acoustics Modular Construction System

Flexible design

Modular components can be assembled to create structures of virtually any size and shape.

Rapid, Clean Installation

Complete IAC Acoustic studio structures can be erected much faster than conventionally built ones, and with minimal mess/disruption.

Predictable, Guaranteed Acoustic Performance

All IAC Acoustic products and components are laboratory tested, allowing the acoustic characteristics of a complete structure to be determined at the design stage.

Portability

One of the most appealing features of IAC Acoustic modular studios is that they can be dismantled, adapted, reconfigured and re-assembled, at any stage - with relative ease, low cost and no loss in acoustic performance.

IAC Acoustics Turnkey Service

IAC Acoustics undertakes the complete design, manufacture and installation of studio structures, including all electrical and mechanical systems (such as air conditioning) and interior decoration. This turnkey service is both efficient and economical, providing finished facilities fit for immediate occupation.

Standard Voice-Over Booths

IAC Acoustics manufactures a range of 6 standard Voice-Over booths - in three basic shapes - all of which combine the benefits of modular construction with added convenience and affordability. Drawings showing the shape and size of these standard units appear on the next page.

The booths have either single or double walls - giving different levels of acoustic isolation - and are fully equipped with acoustic door(s), window(s), lighting, electrics, ventilation, carpet and attractive fabric wall coverings. For a detailed specification please contact us.



Standard Modular Voice-Over Booths

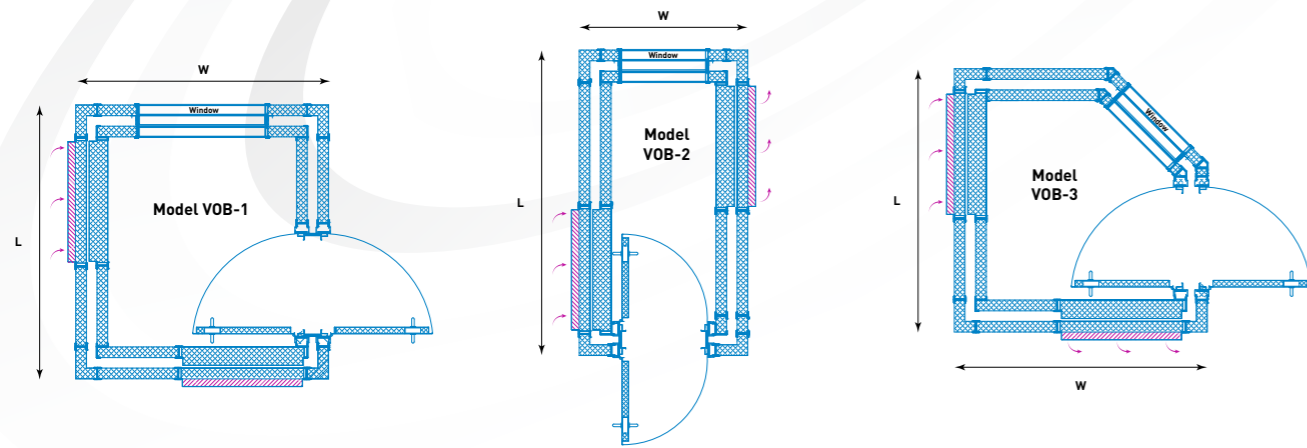

Construction
Double Wall
External Dimensions
2.6m long x 2.4m wide x 2.7m high
Internal Dimensions
2.0m long x 1.8m wide x 2.1m high
Total Weight (approx)
3475kg

Construction
Double Wall
External Dimensions
2.9m long x 1.6m wide x 2.7m high
Internal Dimensions
2.3m long x 1.0m wide x 2.1m high
Total Weight (approx)
2775kg

Construction
Double Wall
External Dimensions
2.5m long x 2.4m wide x 2.7m high
Internal Dimensions
1.9m long x 1.8m wide x 2.1m high
Total Weight (approx)
2975kg

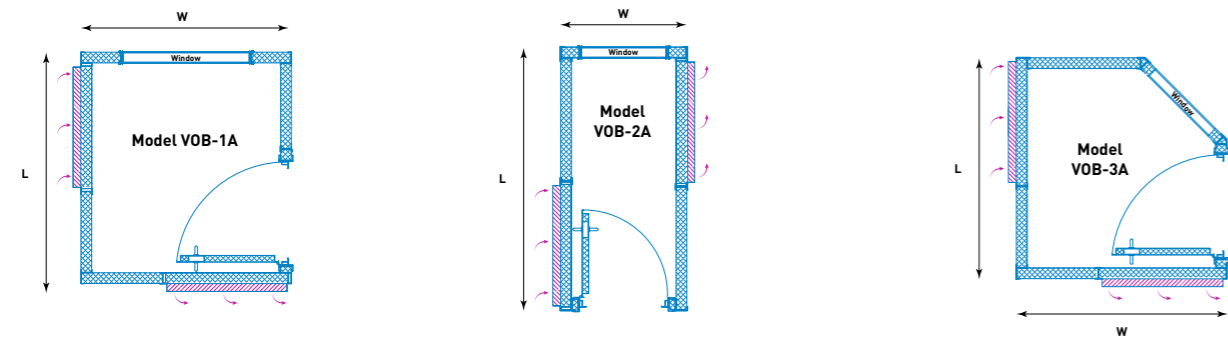

Construction
Single Wall
External Dimensions
2.2m long x 2.0m wide x 2.5m high
Internal Dimensions
2.0m long x 1.8m wide x 2.1m high
Total Weight (approx)
1750kg

Construction
Single Wall
External Dimensions
2.5m long x 1.2m wide x 2.5m high
Internal Dimensions
2.3m long x 1.0m wide x 2.1m high
Total Weight (approx)
1375kg

Construction
Single Wall
External Dimensions
2.1m long x 2.0m wide x 2.5m high
Internal Dimensions
1.9m long x 1.8m wide x 2.1m high
Total Weight (approx)
1500kg

Key

-  IAC Moduline Panel
-  IAC Moduline H-Joiner
-  Vent Panel
-  Airflow Direction

Typical Elevations of Voice-Over Booths

Single walled booth elevations

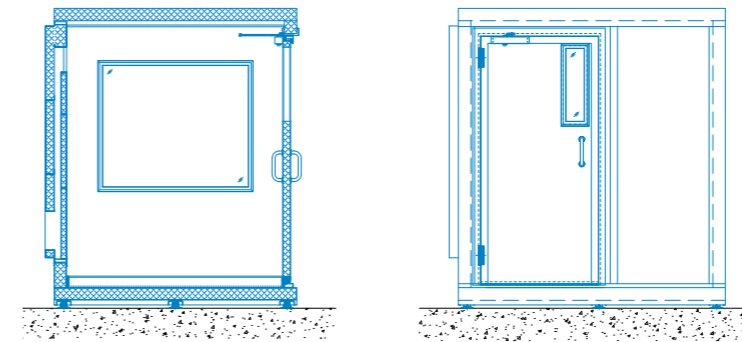

Double walled booth elevations

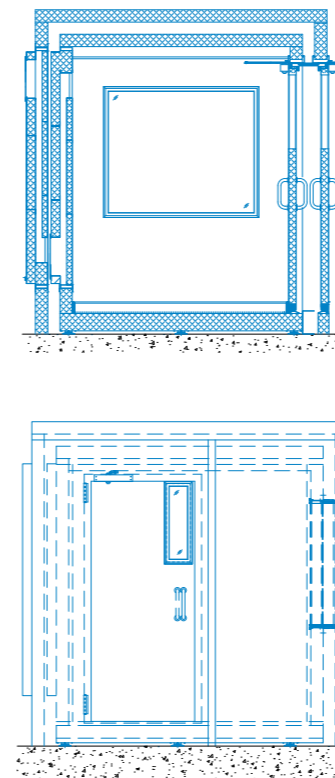

Contacts



Head Office - Winchester, UK

T: +44 (0) 1962 873 000
F: +44 (0) 1962 873 111
E: info@iac-uk.com



Australia

T: +61 (0) 2 8781 0400
F: +61 (0) 2 9725 2939
E: info@iac-australia.com.au



Brazil

T: +55 21 2584 6549
F: +55 21 2584 2457
E: brasil@iac-acoustics.com



Canada

T: +1 (905) 612 4000
F: +1 (905) 612 8999
E: toronto@iac-acoustics.com



China

T: +86 (0) 769 89899966 802
F: +86 (0) 769 89899966 810
E: china.sales@iac-china.com



Denmark

T: +45 36 77 88 00
F: +45 36 78 12 30
E: nordic@iac-acoustics.com



France

T: +33 (0) 3 20 05 88 88
F: +33 (0) 3 20 05 88 99
E: france@iac-acoustics.com



Germany

T: +49 (0) 2163 9991 0
F: +49 (0) 2163 9991 23
E: deutschland@iac-acoustics.com



Italy

T: +39 02 48 44 22 1
F: +39 02 48 44 22 22
E: italia@iac-acoustics.com



Spain

T: +34 93 321 6684
F: +34 93 321 6249
E: espana@iac-acoustics.com



UAE - Dubai

T: +971 42 517 456
F: +971 42 517 457
E: dubai@iac-acoustics.com



USA - Houston

T: +1 (832) 554 0980
F: +1 (832) 554 0990
E: houston@iac-acoustics.com



USA - Lincoln

T: +1 (402) 323 7272
F: +1 (402) 323 7271
E: lincoln@iac-acoustics.com



USA - New York

T: +1 (718) 931 8000
F: +1 (718) 863 1138
E: newyork@iac-acoustics.com



Making the world a quieter place

